

Preparation unit——GA Series



GAFR Series filter & regulator



Symbol

No reflux valve is attached



Reflux valve is attached

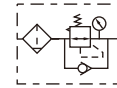

Product feature

1. Circular square pressure gauge which with clip and magnifier is used to save installation space.
2. The pressed-in self-locking mechanism can prevent the abnormal movement of the set pressure caused by external interfere.
3. Balanced design is adopted for the pressure adjustment mechanism.
4. Unique diversion structure spins the air flowing through to effectively separate the liquid from the air and reliably filter the solid grain.
5. The filtering grade includes 5 μ m and 40 μ m (optional).
6. Two drain types are available: semi-auto drain and automatic drain.
7. Three material of bowl are available: PC, Nylon and metal.
8. The bracket can be selected for installation.

Specification

Model	GAFR200-06	GAFR200-08	GAFR300-08	GAFR300-10	GAFR300-15	GAFR400-10	GAFR400-15	GAFR500-20	GAFR600-20	GAFR600-25
Fluid	Air									
Port size [Note1]	1/8"	1/4"	1/4"	3/8"	1/2"	3/8"	1/2"	3/4"	3/4"	1"
Filtering grade	40 μ m or 5 μ m									
Pressure range	0.15~0.9MPa(20~130psi)									
Max. pressure	1.0MPa(145psi)									
Proof pressure	1.5MPa(215psi)									
Temperature range	-5~70°C(Unfreeze)									
Capacity of drain bowl	25CC		60CC		100CC		108CC		205CC	
Weight	290g		500g		880g		950g		1880g	

[Note1] PT thread, G thread and NPT thread are available.

Ordering code

GAFR300 □ 10 □ S □ □ W G K
 ① ② ③ ④ ⑤ ⑥ ⑦ ⑧ ⑨ ⑩

① Model	② Bowl material	③ Port size	④ Drain type	⑤ Type code	⑥ Accessories	⑦ Pressure gauge	⑧ Filtering grade	⑨ Thread type	⑩ Code of reflux valve
GAFR200:GA200 Series Filter & regulator	Blank : PC bowl	06: 1/8"	Blank: Semi-auto drain +Manual drain	S: Standard	Blank: Bracket	Blank: Circular	Blank: 40 μ m	Blank: PT (MPa/psi)	Blank: No reverse flow valve is attached
GAFR300:GA300 Series Filter & regulator		08: 1/4"							
GAFR400:GA400 Series Filter & regulator	C: Metal bowl	10: 3/8"	A: Automatic drain	L: Lower pressure [Note1]	J: No bracket	N: No gauge [Note2]	W: 5 μ m	G: G (bar/MPa)	K: Reverse flow valve is attached [Note2]
GAFR500:GA500 Series Filter & regulator	N: Nylon bowl	15: 1/2"							
GAFR600:GA600 Series Filter & regulator	C: Metal bowl	20: 3/4"		S: Standard				T: NPT (psi/bar)	

[Note1] The work pressure of lower pressure type is 0.15~0.4MPa(20~58psi) ; [Note2] Please refer to page 201 for details of sealing plate Installation and reflux valve.

Inner structure

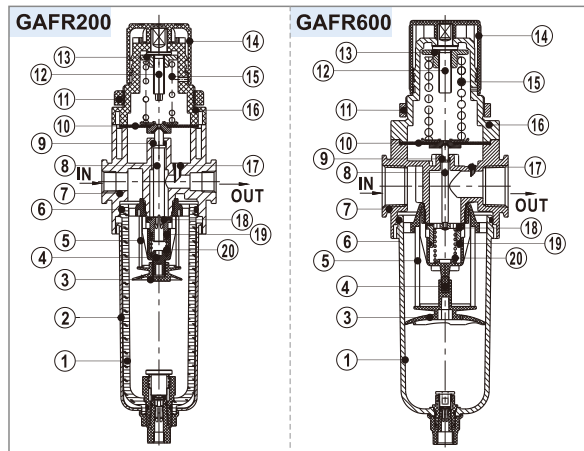

No.	Item	Material
1	Drain bowl	Aluminum alloy \ PC \ Nylon
2	Meter cover	SPCC
3	Umbrella baffle	High viscosity POM
4	Air guider	High viscosity POM
5	Filter core	HDPE
6	O-ring	NBR
7	Body of filter-regulator	Aluminum alloy
8	Adjusting spool	Brass(GAFR600)\POM(others)
9	O-ring	NBR
10	Diaphragm	NBR
11	Fixation ring cap	Aluminum alloy (GAFR600)\POM(others)
12	Adjusting spindle	Steel
13	Regulator nut	Steel
14	Pressure knob	POM
15	Spring	SWPB
16	Adjusting seat	Aluminum alloy (GAFR600)\POM(others)
17	Feedback tube	POM
18	Adjusting plug	Brass & Rubber
19	O-ring	NBR
20	Spring	SWPB



Preparation unit—GA Series



GAFR Series filter & regulator

Pressure chart

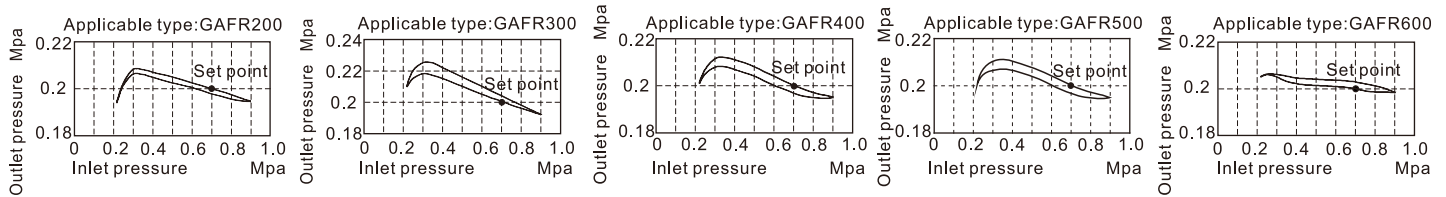

Flow chart

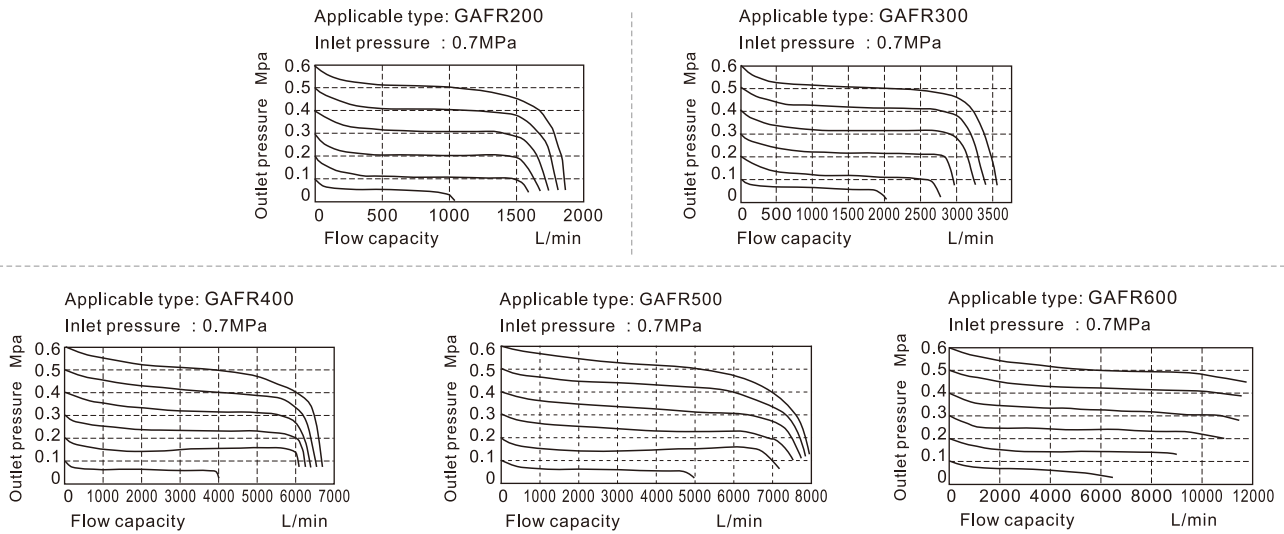

Dimensions

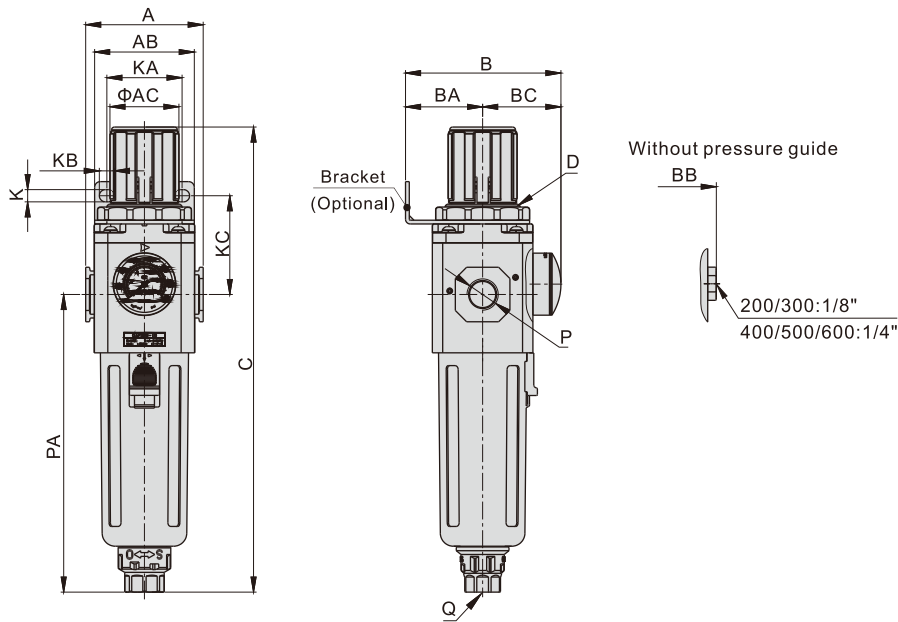

Model/Item	A	AB	AC	B	BA	BB	BC	C	D	K	KA	KB	KC	P	PA	Q
GAFR200-06	52.5	55	31	69	30	55.5	39	192.5	M33x1.5	5.4	34	15.4	52	1/8"	120	M5X0.8
GAFR200-08	52.5	55	31	69	30	55.5	39	192.5	M33x1.5	5.4	34	15.4	52	1/4"	120	M5X0.8
GAFR300-08	62.5	53	38	82.5	41	71.5	41.5	247	M40x1.5	6.5	40	8	52.5	1/4"	158	G1/4
GAFR300-10	62.5	53	38	82.5	41	71.5	41.5	247	M40x1.5	6.5	40	8	52.5	3/8"	158	G1/4
GAFR300-15	62.5	53	38	82.5	41	71.5	41.5	247	M40x1.5	6.5	40	8	52.5	1/2"	158	G1/4
GAFR400-10	80	72	52	99	50	88	49	285.5	M55x2.0	8.5	55	11	57	3/8"	177.5	G1/4
GAFR400-15	80	72	52	99	50	88	49	285.5	M55x2.0	8.5	55	11	57	1/2"	177.5	G1/4
GAFR500-20	82	72	52	100	50	89	50	299.5	M55x2.0	8.5	55	11	57	3/4"	191.5	G1/4
GAFR600-20	100	90	59	128	70	117	58	336.5	M62x1.5	11	66	13	76	3/4"	205	G1/4
GAFR600-25	100	90	59	128	70	117	58	336.5	M62x1.5	11	66	13	76	1"	205	G1/4

